



The HXM plate mounted axial flow fans are manufactured from pressed galvanised steel protected from corrosion by a beige epoxy-polyester paint finish. HXM models include impellers manufactured from aluminium sheet (HXM-200 to HXM-350) or steel sheet (HXM-400), finished with black polyester paint. All models include a steel finger proof guard as standard mounted to the inlet side of the fan.

**Motor**

HXM-200 to HXM-350: Single phase speed controllable motor 230V-50/60Hz equipped with thermal protection, IP44, Class B insulation, flexible cable (length: 50cm) for connection to the electrical supplies and ball bearings greased for life.

HXM-400: External rotor motor, IP44, Class F insulation, fitted with thermal protection and wiring terminal box.

**Additional Information**

Standard air direction: form (A) configuration (Motor over Impeller).



Configuration model HXM-400



**Provided with cable for connection to the electrical supplies**

Motor protected from corrosion by epoxy-polyester paint finish. Cable to ease connection to electrical supplies (except for HXM-400 model).



**HXM-400 model terminal box**

Wiring terminal box including the capacitor.

### TECHNICAL CHARACTERISTICS

Before making any electrical connection ensure that the voltage and frequency of the mains electrical supply matches that of the fan data plate label.

Model	Speed (rpm)	Diameter (mm)	Maximum absorbed power (W)	Maximum absorbed current (A)	Sound pressure level* (dB(A))	Maximum air volume (m³/h)	Working temperature (°C)	Weight (kg)	Speed controller	
									REB	RMB
HXM-200	1345	200	19	0,1	42	530	-15/+40	1,8	REB-1N	RMB-1,5
HXM-250	1340	250	28	0,1	46	790	-15/+40	2,4	REB-1N	RMB-1,5
HXM-300	1320	300	39	0,2	50	1.150	-15/+40	3,2	REB-1N	RMB-1,5
HXM-350	1360	350	50	0,2	53	1.675	-15/+40	4,3	REB-1N	RMB-1,5
HXM-400	1255	400	151	0,7	56	3.670	-40/+60	9,0	REB-1N	RMB-1,5

\* Sound pressure measured in free field condition at 1,5 m.

### ACOUSTIC CHARACTERISTICS

Model	63	125	250	500	1.000	2.000	4.000	8.000	LwA
HXM-200	35	48	48	52	48	46	41	28	56
HXM-250	32	46	53	58	53	52	46	32	61
HXM-300	31	43	51	58	55	54	48	35	61
HXM-350	43	55	61	62	57	55	48	36	66
HXM-400	43	61	63	63	64	63	58	50	70

### DIMENSIONS (mm)

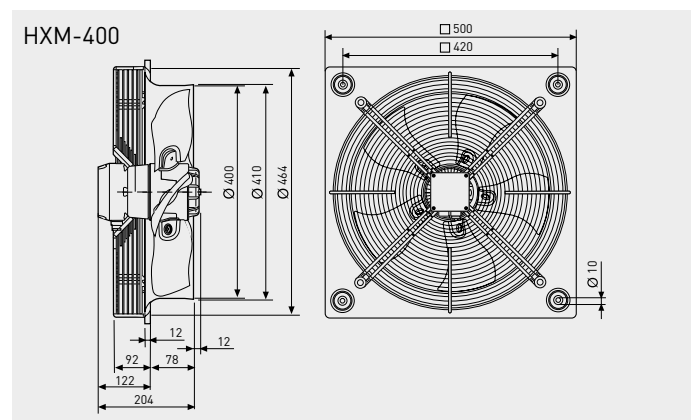
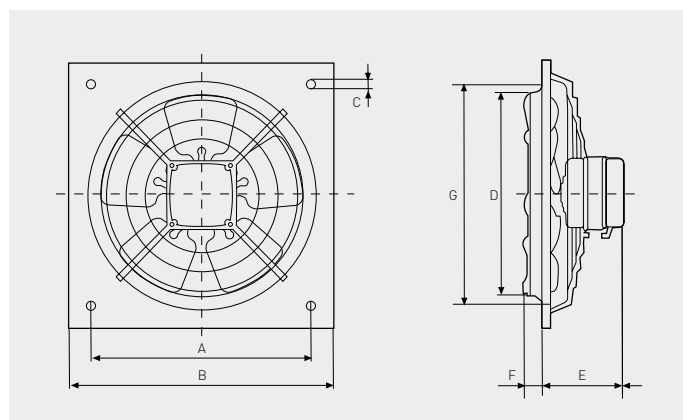

Model	∅ A	∅ B	∅ C	∅ D	E	F	∅ G
HXM-200	222,5	266	9,5	205	88	19,5	211
HXM-250	275,5	333	9,5	255	99	31,5	261
HXM-300	336,5	400	10,5	305	99	35,5	311
HXM-350	390,5	465	10,5	361	106	34,5	371

**PERFORMANCE CURVES**

- $q_v$ : Airflow in  $m^3/h$  and  $m^3/s$ .
- $p_{sf}$ : Static pressure in Pa.
- $p_g$ : Protection guard pressure drop in Pa.
- SFP: Specific fan power in  $W/m^3/s$ .
- P: Absorbed power in W.
- Measurement category: A.
- Efficiency category: static.
- Fan efficiency without speed control.
- Fan tested without protection guard.
- Airflow data in accordance with ISO 5801.
- Sound pressure levels in dB(A), measured at 1,5 meters in free field.

- MC** Measurement category
- EC** Efficiency category
- VSD** Speed control: supplied with the fan
- SR** Specific ratio
- $\eta$ [%]** Efficiency
- N** Efficiency grade
- [ $m^3/h$ ]** Airflow
- [Pa]** Static pressure
- [RPM]** Speed

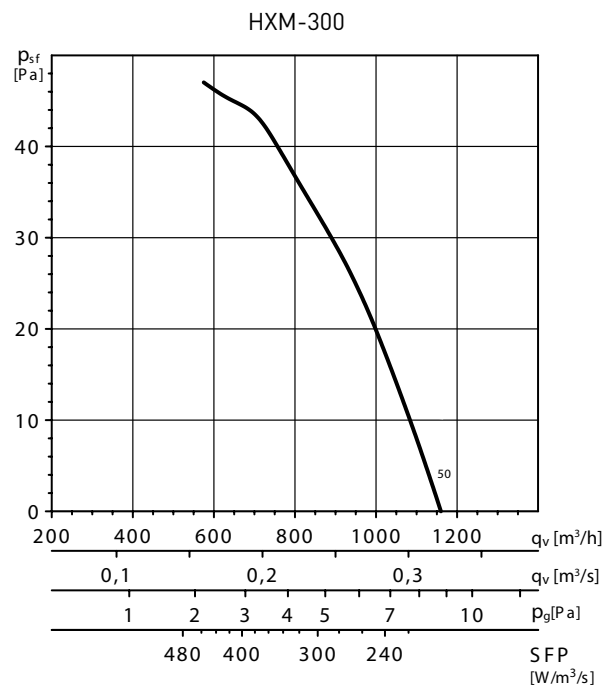
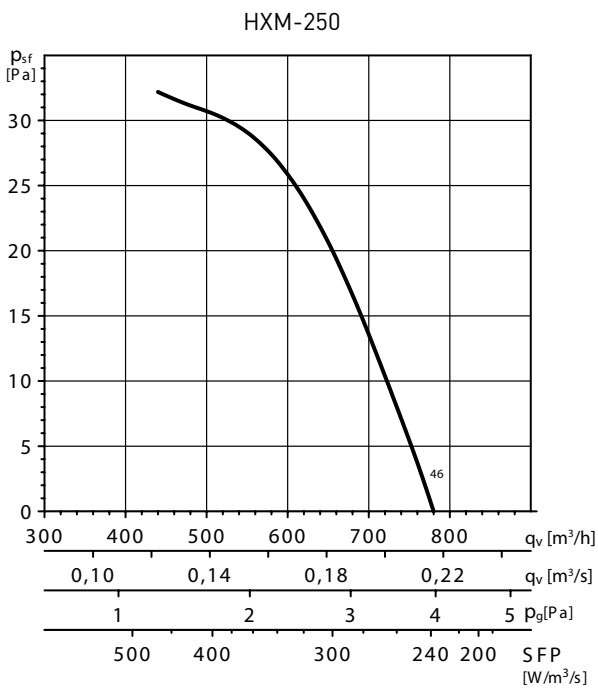
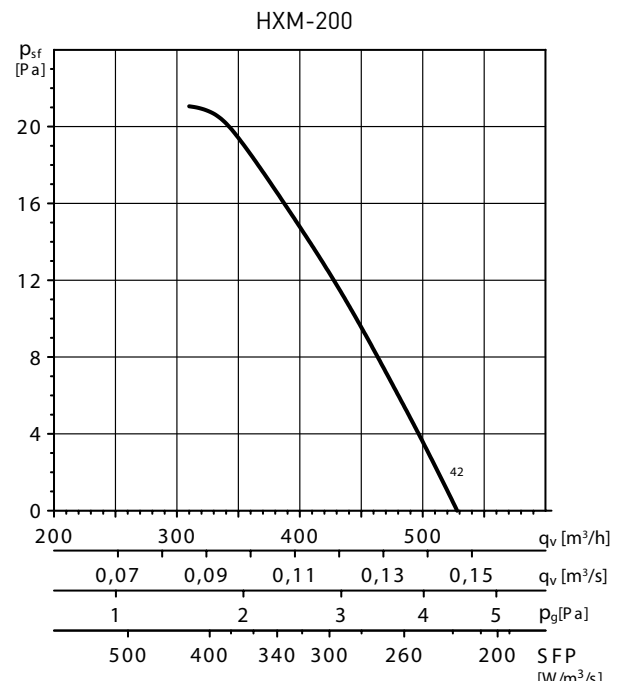

PERFORMANCE CURVES

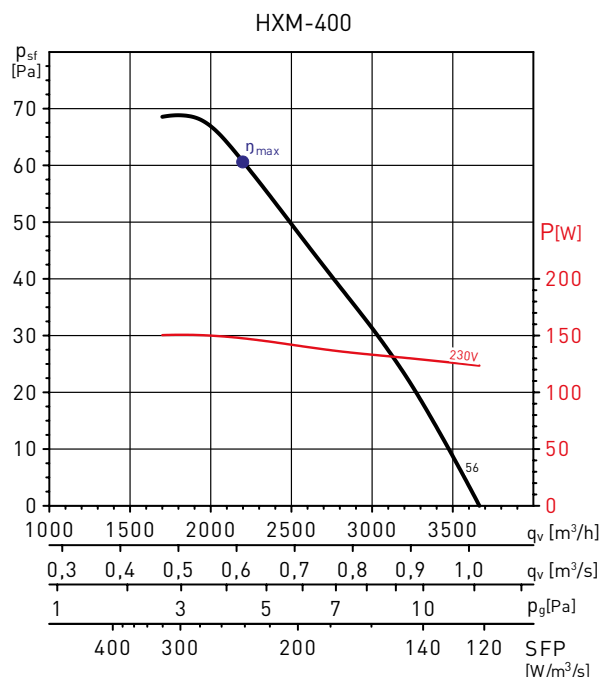
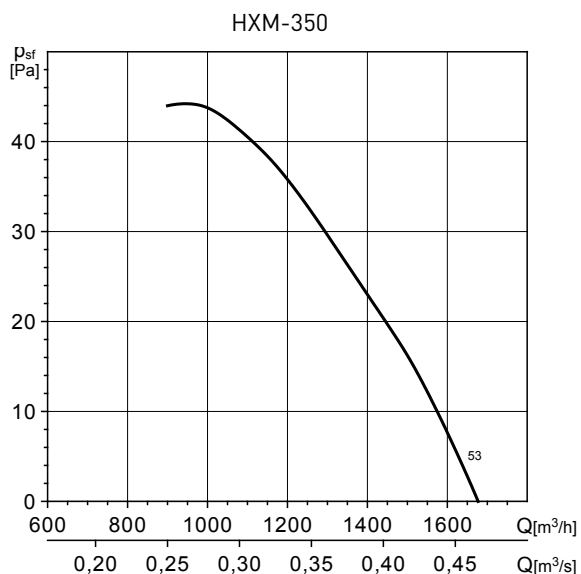

MC*	EC*	VSD*	SR*	$\eta$ [%]*	N*	[kW]	$q_v$ [m³/h]	[Pa]	[RPM]
B	Static	No	1,001	25,1	36,7	0,148	2198	61	1103

\* See example curve.

MOUNTING ACCESSORIES



**PER-W**  
Back draft plastic shutters.



**PER-CR**  
Back draft aluminium shutters.

Model	Back draft shutters	
	Plastic	Metal
HXM-200	PER - 200 W	PER - 250 CR
HXM-250	PER - 250 W	PER - 250 CR
HXM-300	PER - 355 W	PER - 355 CR
HXM-350	PER - 355 W	PER - 355 CR
HXM-400	PER - 400 W	PER - 400 CR

ELECTRICAL ACCESSORIES



**REB**  
Electronic, single phase speed controller.



**RMB**  
Auto transformer, single phase speed controller.