



Axial jet fans to induce air movement in enclosed car parking, tunnels and large spaces. Suitable for ventilation and one off emergency smoke operation at F400 or F300. TJHT series: reversible. TJHU series: unidirection.

**Description**

Diameters from:  
TJHT series: 315 to 630mm, fully reversible.  
TJHU series: 315 to 400mm, unidirection.  
Impeller is cast aluminum alloy in accordance with EN 1706, and balanced in accordance with ISO 14694: G 6.3.  
Fan duct and 2 mounting feet are steel in accordance with EN 10130-99, and hot dip galvanized in accordance with EN 1461: 1999.  
Fan external electrical terminal box.  
Two circular sound attenuators in galvanized sheet steel, with flared inlet and acoustic media.  
Supplied with inlet and outlet steel guard. Impeller with 6 (TJHT) or 7 (TJHU) blades. Fan approved in accordance EN12101-3. For transportation, size up to 400 is supplied complete. Diameter from 450 to 630 can be supplied in 3 pieces.

**Motors**

TJHT series: IEC, from 80 to 160, 3 phase 400V-50Hz, IP55, Class H, F400-120 and F300-120.  
TJHU series: IEC, from 80 to 90, 3 phase 400V-50Hz, IP55, Class H, F400-120 and F300-120. Class F at F200-120.  
Two speed 2/4 pole Dalhander winding.  
Ambient temperature: -20°C to +40°C.  
Working temperature from -20°C to +40°C.

**On request**

Single speed 2 pole motor.  
Inlet guard and steel discharge deflector for unidirectional airflow.  
Inlet and outlet steel discharge deflector for reversible airflow.  
Factory fitted IP65 isolator in place of electrical terminal box. Isolator also available as an accessory for use with standard terminal box fan.  
External painting to RAL colour.

**Specific applications**



Officially approved to EN12101-3. 0370-CPD-0672 0370-CPD-1481

Officially approved to EN12101-3. 0370-CPD-0673 0370-CPD-1422. (tested F300-120)

Officially approved to EN12101-3. 0370-CPD-1317 0370-CPD-0775



Parkings



Tunnels



Two protection guards fitted as standard.

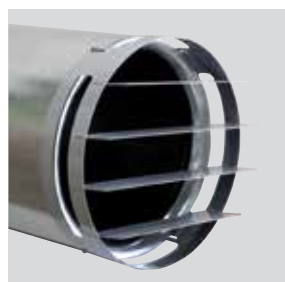

Optional deflector on outlet for uni direction, or inlet and outlet for reversible.



External terminal box for ease of connection.



Optional isolator Electrical isolator fitted to fan for security or as an accessory.

### REFERENCE

<b>T</b>	<b>J</b>	<b>H</b>	<b>T</b>	/	<b>2/4</b>	-	<b>6</b>	<b>3</b>	<b>0</b>	<b>C/I</b>	<b>16/4</b>	<b>F400</b>	<b>400 V</b>	<b>50 Hz</b>
1					2		3			4	5	6	7	8

- 1 - Series: TJHT reversible, TJHU unidirection, for emergency smoke operation and ventilation.
- 2 - Motor speed (rpm).
- 3 - Nominal diameter.
- 4 - C = Terminal box (standard). I = Isolator (optional).
- 5 - Emergency operation designation.
- 6 - Temperature class.
- 7 - Nominal electrical supply.
- 8 - Frequency (Hz).

### TECHNICAL CHARACTERISTICS

Before installation check that the product electrical characteristics listed on the data plate label (voltage, power, frequency, etc.) match those of the intended electrical supply.

Model	Speed (rpm)	Thrust (N)	Airflow (m³/h)	Air velocity (m/s)	Motor power* (kW)	Maximum absorbed current (A)	Sound pressure level** (LpA)		Weight (kg)
							Form A***	Form B***	
<b>TJHT REVERSIBLE - 1 speed 2 POLE</b>									
TJHT/2-315-CN	2790	24	4.500	16	0,75	1,6	71	64	57
TJHT/2-355-CN	2810	40	6.500	18	1,1	2,3	74	67	76
TJHT/2-400-CN	2870	60	9.000	20	1,5	4,2	79	71	89
TJHT/2-450-C	2840	85	12.100	21	2,2	4,5	82	74	133
TJHT/2-500-C	2890	144	17.500	25	4	7,5	85	78	165
TJHT/2-560-C	2925	235	25.000	28	7,5	13,6	88	81	220
TJHT/2-630-C	2945	387	36.100	33	15	27	90	83	290
<b>TJHT REVERSIBLE - 2 speed 2/4 POLE</b>									
TJHT/2/4-315-CN	2820/1400	24	4.500	16	0,8/0,2	1,9/0,6	71/56	64/49	57
TJHT/2/4-355-CN	2810/1390	40	6.500	18	1,1/0,25	2,4/0,75	74/59	67/52	76
TJHT/2/4-400-CN	2900/1435	60	9.000	20	1,5/0,37	4,2/1,3	79/64	71/56	89
TJHT/2/4-450-C	2845/1420	85	12.100	21	2,2/0,5	4,6/1,5	82/67	74/59	134
TJHT/2/4-500-C	2890/1440	144	17.500	25	4,4/1,1	8,6/2,8	85/70	78/63	166
TJHT/2/4-560-C	2930/1470	235	25.000	28	8/2	15,3/4,8	88/73	81/66	223
TJHT/2/4-630-C	2950/1470	387	36.100	33	16/4	30,5/9,6	90/75	83/68	311
<b>TJHU UNIDIRECTIONAL - 1 speed 2 POLE</b>									
TJHU/2-315-C	2790	25	4.600	16	0,75	1,6	-	62	56
TJHU/2-355-C	2810	43	6.800	19	1,1	2,3	-	66	75
TJHU/2-400-C	2870	68	9.700	21	1,5	3	-	70	88
<b>TJHU UNIDIRECTIONAL - 2 speed 2/4 POLE</b>									
TJHU/2/4-315-C	2820/1400	25	4.600	16	0,8/0,2	1,9/0,6	-	62/46	56
TJHU/2/4-355-C	2810/1390	43	6.800	19	1,1/0,25	2,4/0,75	-	66/49	75
TJHU/2/4-400-C	2900/1435	68	9.700	21	1,5/0,37	3,5/1,3	-	70/55	88

\* May depend on motor used.

\*\* Sound pressure at 3m, hemispherical propagation, in free field conditions, for comparison.

\*\*\* TJHT series: Form A air over motor > impeller, Form B air through impeller > motor. TJHU series: Form B only.

**DIMENSIONS (mm)**

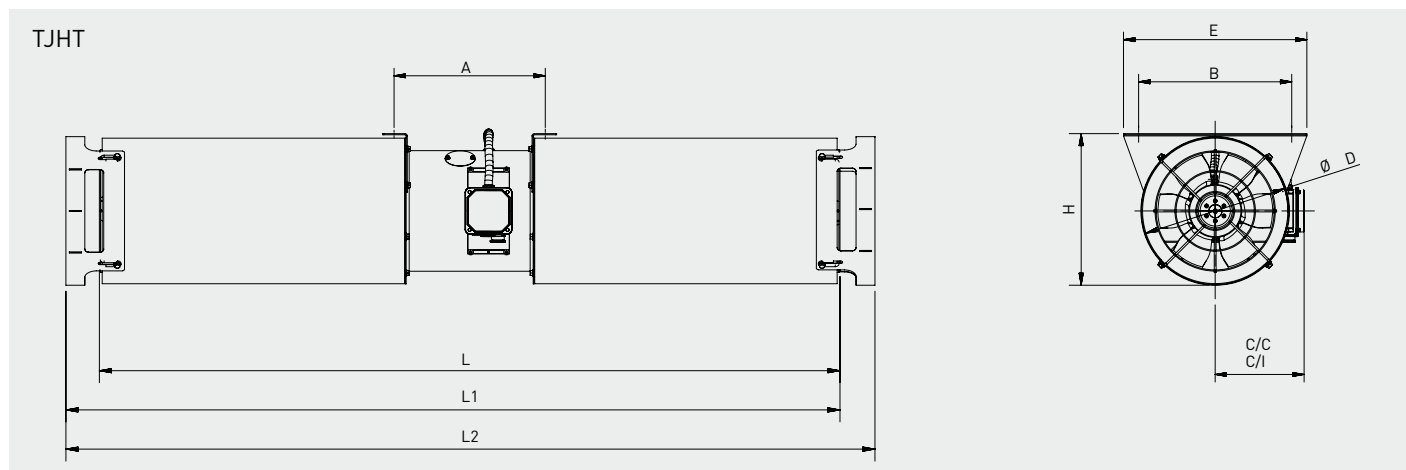

L: standard with guards, no deflector. L1: for unidirection with 1 deflector. L2: for reversible with 2 deflectors. C/C: version with terminal box (standard). C/I: version with isolator (optional).

Model	A	B	C/C	C/I	D	E	H	L	L1	L2
315	310	405	236	279	385	485	397	1754	1810	1967
355	310	445	259	302	425	525	437	1754	1810	1967
400	310	506	283	326	486	586	498	1754	1810	1967
450	539	556	313,5	362,5	536	636	548	2499	2055	2712
500	549	620	343,5	392,5	600	700	612	2499	2055	2712
560	669	680	376	425	660	760	672	3019	3072	3232
630	769	750	422	480	730	830	742	3119	3175	3332

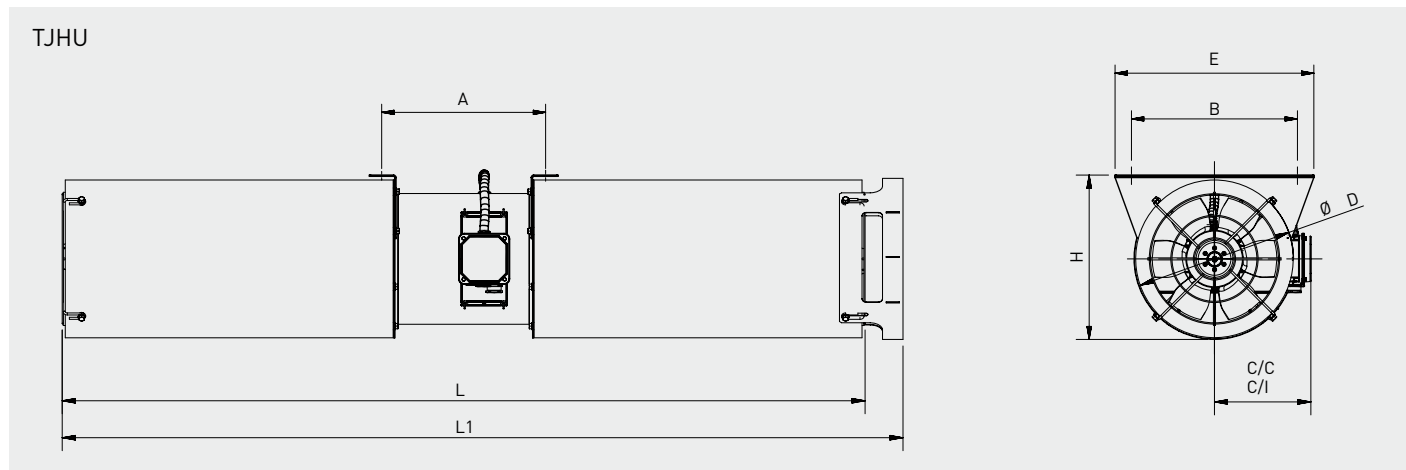

L: standard with guards, no deflector. L1: for unidirection with 1 deflector. C/C: version with terminal box (standard). C/I: version with isolator (optional).

Model	A	B	C/C	C/I	D	E	H	L	L1
315	310	405	236	279	385	485	397	1754	1810
355	310	445	259	302	425	525	437	1754	1810
400	310	506	283	326	486	586	498	1754	1810

### ACOUSTIC CHARACTERISTICS

Sound power levels LwA ref. 1pW tested in accordance with ISO 13347:2004.

#### TJHT (2 pole)

Form A	63	125	250	500	1000	2000	4000	8000	LwA
315	59	68	84	73	75	76	72	66	86
355	62	71	87	76	78	79	75	69	89
400	68	76	92	80	82	81	76	69	93
450	70	78	95	84	86	86	83	76	97
500	73	82	98	87	89	90	86	80	100
560	74	83	100	90	92	94	92	86	102
630	80	89	105	94	96	97	93	87	107

#### TJHT (4 pole)

Form A	63	125	250	500	1000	2000	4000	8000	LwA
315	44	53	69	58	60	61	57	51	71
355	47	56	72	61	63	64	60	54	74
400	53	61	77	65	67	66	61	54	78
450	55	63	80	69	71	71	68	61	82
500	58	67	83	72	74	75	71	65	85
560	59	68	85	75	77	79	77	71	87
630	65	74	90	79	81	82	78	72	92

Form B	63	125	250	500	1000	2000	4000	8000	LwA
315	59	65	75	67	70	71	68	63	79
355	62	68	78	70	73	74	71	66	82
400	67	73	83	74	76	76	72	66	85
450	70	76	85	77	81	82	78	73	89
500	73	79	89	81	84	85	82	77	93
560	75	81	90	83	88	90	87	83	96
630	80	86	96	88	91	92	89	84	100

Form B	63	125	250	500	1000	2000	4000	8000	LwA
315	44	50	60	52	55	56	53	48	64
355	47	53	63	55	58	59	56	51	67
400	52	58	68	59	61	61	57	51	70
450	55	61	70	62	66	67	63	58	74
500	58	64	74	66	69	70	67	62	78
560	60	66	75	68	73	75	72	68	81
630	65	71	81	73	76	77	74	69	85

#### TJHU (2 pole)

Form B	63	125	250	500	1000	2000	4000	8000	LwA
315	61	63	71	72	75	72	66	61	79
355	64	66	75	75	78	76	70	64	83
400	67	71	76	77	82	81	76	70	86

#### TJHU (4 pole)

Form B	63	125	250	500	1000	2000	4000	8000	LwA
315	40	56	54	58	56	50	45	38	63
355	44	59	58	60	61	54	49	42	66
400	46	63	62	69	62	60	55	46	72

### ACCESSORIES



**INT-25/6P-F400**  
**INT-40/6P-F400**  
 Isolator ON / OFF, approved at F400-120.  
 Aluminium covering.  
 Maximum ampere:  
 25A (model INT-25/6P-F400)  
 40A (model INT-40/6P-F400)  
 For use with motors 3 phase  
 380 - 420V.  
 Frequency: 50 - 60Hz.  
 IP65.

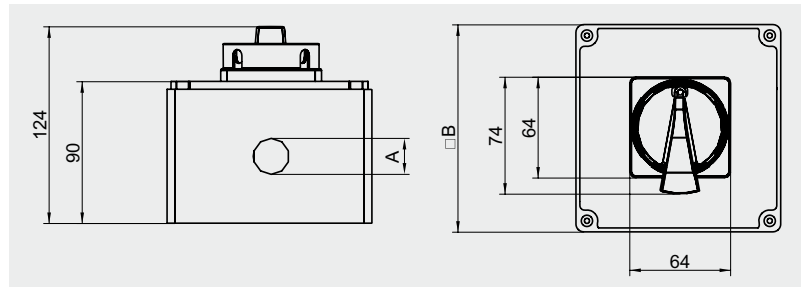

Model	A	B
INT-25/6P-F400	M25	130
INT-40/6P-F400	M32	160