



Range of single inlet direct driven centrifugal fans designed for smoke extraction in fire conditions and certified F400-120 (CE marked) and suitable for the continuous extraction of air stream up to 120°C.

The CXRT range is supplied with galvanized steel plate housing mounted with Pittsburgh system.

Welded backward curved centrifugal impellers protected by epoxy paint.

Motors

All motors are IP55, Class F.
 2, 4, 6 or 8 pole, depending on version.
 2 speed models (2/4, 4/6, 4/8, 6/8 and 6/12).
 Electrical supply:

Three phase 230/ 400V-50Hz up to 3 kW.
 400V-50Hz for higher motor powers and 2 speed motors.
 [See characteristics chart].

Additional information

The scroll can be orientated in 3 different positions as per the table below.
 Standard supplied position: RD0.

On request

Fan supplied in LG positions.
 Versions protected against corrosion by epoxy paint coating.
 Fan fitted with 2-speed motor.

Specific applications



Approved to EN112101-3 standard
 Certificate n° 0402-CPD-453801



Continuous



Parkings



Industrial and commercial kitchens



Watertight scroll

Range of fans supplied as standard with housing mounted with the Pittsburgh system ensuring water tightness.

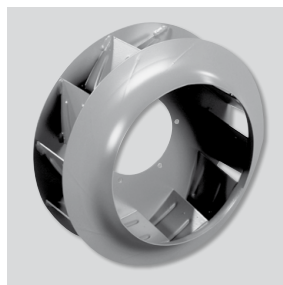

Welded impeller, dynamically balanced

Backward curved centrifugal impellers, protected with epoxy paint coating and dynamically balanced, according to ISO 1940 standard, providing vibration free operation.

POSITIONS

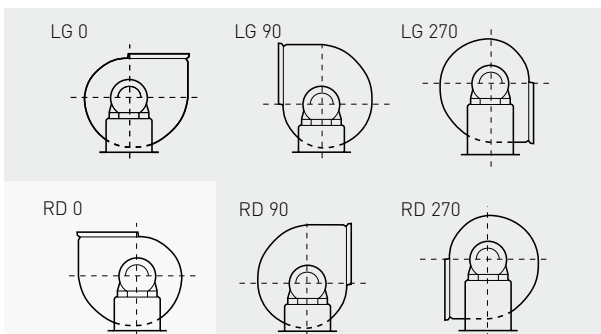

Standard supplied position: RD 0. Special versions are supplied under request.

TECHNICAL CHARACTERISTICS

Before installation check that the product electrical characteristics listed on the data plate label (voltage, power, frequency, etc.) match those of the intended electrical supply.

Model	Speed (rpm)	Motor power (kW)	Rated current 400V (A)	Maximum airflow (m ³ /h)	Maximum temperature (°C)	Weight (kg)
2 POLE						
CXRT/2-315-1,5	2870	1,5	3,01	4.750	120	35
CXRT/2-355-2,2	2840	2,2	4,48	6.600	120	47,5
CXRT/2-400-4	2890	4	7,55	9.500	120	67,5
4 POLE						
CXRT/4-315-0,25	1410	0,25	0,71	2.300	120	27
CXRT/4-355-0,37	1395	0,37	1,04	3.200	120	35
CXRT/4-400-0,55	1430	0,55	1,36	4.700	120	44
CXRT/4-450-1,1	1440	1,1	2,53	6.700	120	54,5
CXRT/4-500-1,5	1420	1,5	3,19	9.600	120	68
CXRT/4-560-3	1410	3	5,94	13.600	120	91,5
CXRT/4-630-5,5	1470	5,5	10,6	19.500	120	132
CXRT/4-710-11	1455	11	21	27.900	120	196
6 POLE						
CXRT/6-450-0,37	930	0,37	1,23	4.400	120	52,5
CXRT/6-500-0,55	930	0,55	1,62	6.300	120	63,5
CXRT/6-560-1,1	925	1,1	2,82	9.000	120	86,5
CXRT/6-630-2,2	940	2,2	5,36	12.800	120	120
CXRT/6-710-3	960	3	6,82	18.400	120	175,5
8 POLE						
CXRT/8-560-0,37	695	0,37	1,37	6.800	120	83,5
CXRT/8-630-0,75	705	0,75	2,42	9.500	120	114
CXRT/8-710-1,1	700	1,1	3,38	13.300	120	146,5
2/4 POLE						
CXRT/2/4-315-1,5/0,37	2830/1380	1,5 / 0,37	3,78 / 1,25	4700/2300	120	83,5
CXRT/2/4-355-2,2/0,5	2880/1410	2,2 / 0,5	4,91 / 1,65	6600/3200	120	114,0
CXRT/2/4-400-4,5/1,1	2900/1430	4,5 / 1,1	8,94 / 2,85	9500/4700	120	146,5
4/6 POLE						
CXRT/4/6-315-0,3/0,1	1435/955	0,3 / 0,1	0,99 / 0,72	2300/1600	120	25
CXRT/4/6-355-0,55/0,2	1450/970	0,55 / 0,2	1,69 / 0,97	3200/2200	120	39,5
CXRT/4/6-400-0,75/0,22	1430/970	0,75 / 0,22	1,98 / 1,29	4700/3200	120	46,5
CXRT/4/6-450-1,1/0,3	1440/970	1,1 / 0,3	3,02 / 1,43	6700/4400	120	61,5
CXRT/4/6-500-1,5/0,45	1420/965	1,5 / 0,37	3,71 / 1,73	9600/6300	120	73,5
CXRT/4/6-560-3/1	1460/980	3 / 1	6,83 / 4,1	13600/9000	120	103,5
CXRT/4/6-630-6/2,2	1460/985	6 / 2,2	13,6 / 7,2	19500/12800	120	171
CXRT/4/6-710-10/3,3	1460/985	10 / 3,3	20 / 7,6	27900/18400	120	240,5
4/8 POLE						
CXRT/4/8-315-0,6/0,15	1435/710	0,6 / 0,15	20 / 7,6	2300/1200	120	34
CXRT/4/8-355-0,6/0,15	1435/710	0,6 / 0,15	20 / 7,6	3200/1600	120	44,5
CXRT/4/8-400-0,6/0,15	1435/710	0,6 / 0,15	20 / 7,6	4700/2400	120	50,5
CXRT/4/8-450-1,2/0,3	1420/710	1,2 / 0,3	20 / 7,6	6700/3400	120	56,5
CXRT/4/8-500-1,6/0,4	1420/710	1,6 / 0,4	20 / 7,6	9600/4400	120	70
CXRT/4/8-560-3,8/1	1450/710	3,8 / 1	20 / 7,6	13600/6800	120	105,5
CXRT/4/8-630-7,2/1,8	1440/725	7,2 / 1,8	20 / 7,6	19500/9500	120	172
CXRT/4/8-710-11/3	1465/725	11 / 3	20 / 7,6	27900/13300	120	239,5
6/8 POLE						
CXRT/6/8-450-0,37/0,2	940/685	0,37 / 0,2	1,51 / 1,06	4400/3400	120	58,5
CXRT/6/8-500-0,55/0,14	960/730	0,55 / 0,14	2,08 / 1,15	6300/4400	120	74
CXRT/6/8-560-1,1/0,55	965/725	1,1 / 0,55	3,59 / 2,52	9000/6800	120	94,5
CXRT/6/8-630-2,2/1,3	960/710	2,2 / 1,3	5,96 / 4,36	12800/9500	120	130
CXRT/6/8-710-3/0,75	975/735	3 / 0,75	7,96 / 3,75	18400/13300	120	187,5
6/12 POLE						
CXRT/6/12-710-3/0,55	970/480	3 / 0,55	6,77 / 2,33	18400/9200	120	182,5

DIMENSIONS

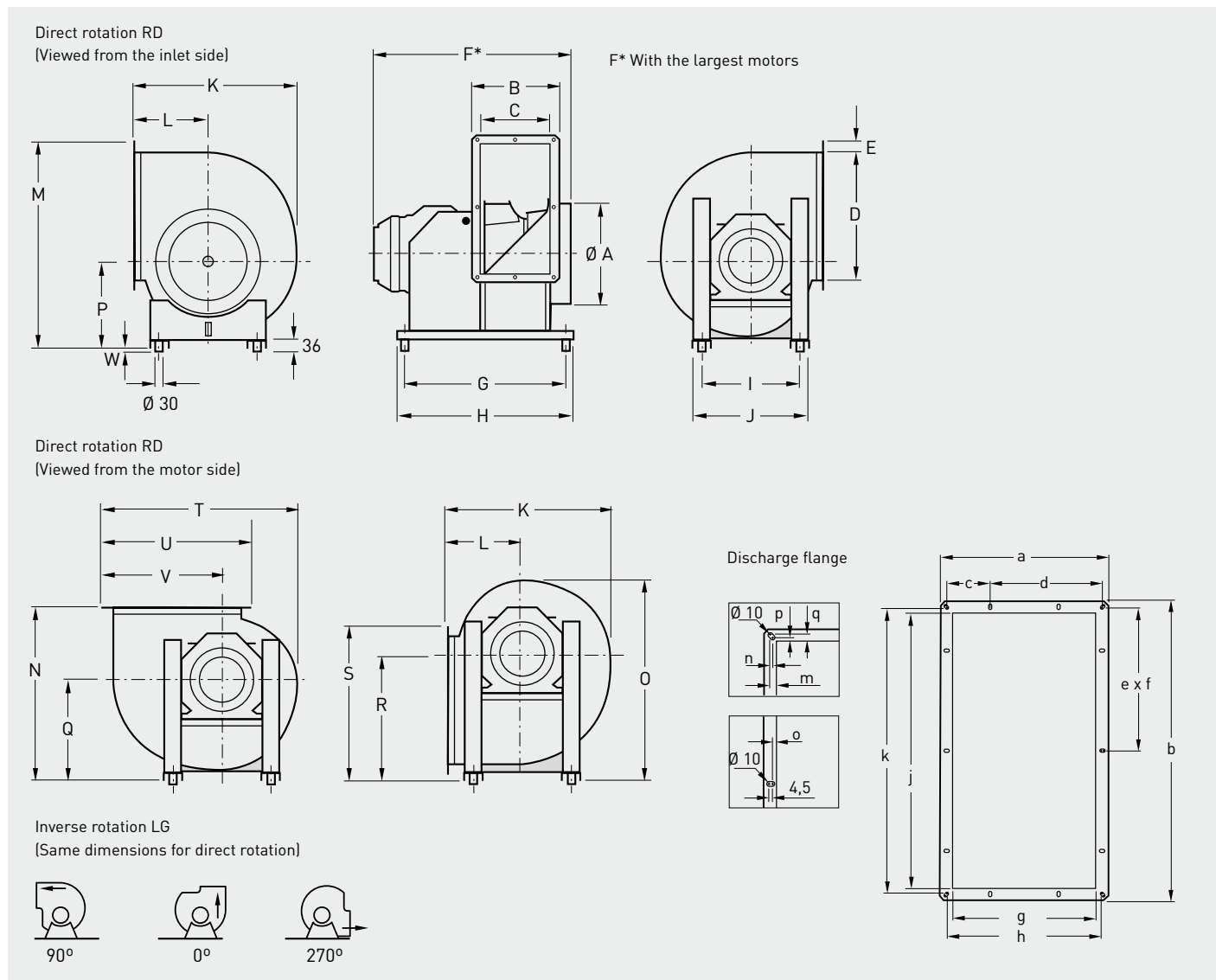

Model	A	B	C	D	E	F	G	H	I	J	K	L	M	N	O	P	Q	R	S	T	U	V	W	Weight without motor
315	310	277	212	404	30	591	507	537	280	320	518	236	646	533	617	275	297	384	477	604	464	371	21	18
355	342	302	236	453	30	685	564	617	335	395	579	261	714	606	699	299	345	436	534	678	513	415	11	28,3
400	388	329	263	507	30	750	589	639	355	415	648	290	793	678	784	329	386	489	593	759	567	464	11	34,2
450	445	359	293	569	30	777	615	665	370	430	725	322	878	786	876	361	464	543	655	851	632	517	11	41,2
500	495	394	328	638	30	895	776	826	390	450	800	352	972	825	969	400	473	593	726	939	695	570	11	50,7
560	562	435	368	715	30	975	820	870	390	450	891	390	1081	917	1074	444	527	659	799	1051	774	636	11	67,4
630	620	477	409	801	30	1018	864	914	447	508	998	434	1204	1028	1198	493	596	732	880	1174	859	711	11	91,9
710	710	526	458	898	30	1067	923	973	518	579	1119	485	1354	1147	1348	557	662	823	981	1322	956	797	11	120,5

Discharge flange

Model	a	b	c	d	e	f	g	h	j	k	m	n	o	p	q
315	277	464			2	217	217	247	404	434	19,5	15	15	15	19,5
355	302	513			2	241,5	242	272	453	483	15	4,5	10,5	15	10,5
400	329	567	149,5		4	134,3	269	299	507	537	19,5	15	15	15	19,5
450	359	629	164,5		4	149,8	299	329	569	599	19,5	15	15	15	19,5
500	394	698	182		4	167	334	364	638	668	19,5	15	15	15	19,5
560	435	775	109,3	186,3	4	186,3	375	405	715	745	19,5	15	15	15	19,5
630	477	861	119,6	207,8	4	207,8	417	447	801	831	19,5	15	15	15	19,5
710	526	958	132	232	4	232	466	496	898	928	19,5	15	15	15	19,5

PERFORMANCE CURVES – RECOMMENDED DATA SELECTION

Performance curves are applicable for airflows whose density is 1,2 kg/m³.

- ① = Airflow in m³/s
- ② = Airflow in m³/h
- ③ = Total pressure in Pa and in mmWG
- ④ = Fan performance η , %
- ⑤ = Sound power level in LwA
- ⑥ = Motor power absorbed at the fans shaft P(kW)
- ⑦ = Dynamic pressure at the discharge side Pd
- ⑧ = Resistance at free inlet, Δp_1
- ⑨ = Resistance at free discharge, $\Delta p_2 + p_d$
- ⑩ = Resistance at inlet guard/protection guard, Δp_3
- ⑪ = Resistance at inlet discharge, Δp_4

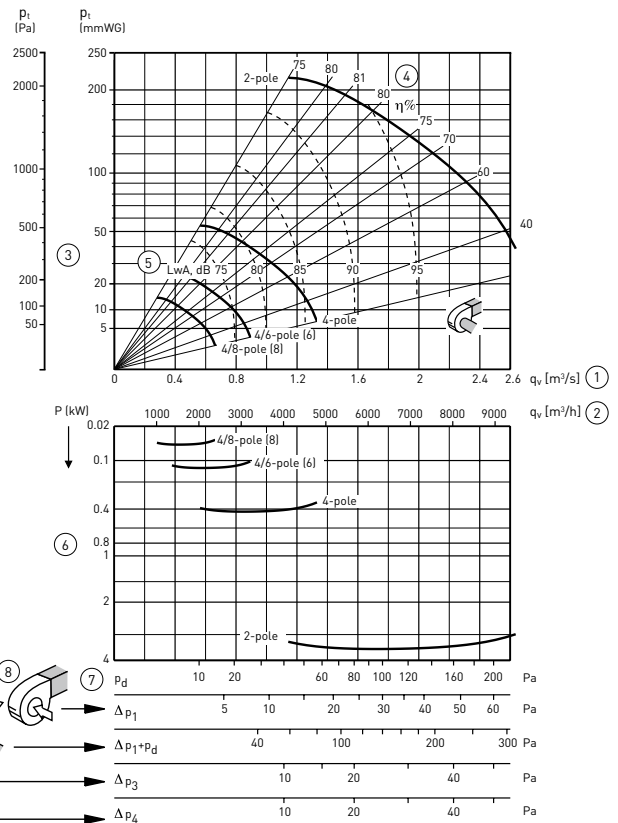

1 mmWG = 9,8 Pa

ACOUSTIC CHARACTERISTICS

The sound levels shown in the curves are sound power levels at the outlet of ducted fans. The following table gives the corrections in order to obtain the spectrums sound power (LwA).

Model	Position /POLES	63 Hz				125 Hz				250 Hz				500 Hz				1000 Hz				2000 Hz				4000 Hz				8000 Hz			
		2P	4P	6P	8P	2P	4P	6P	8P	2P	4P	6P	8P	2P	4P	6P	8P	2P	4P	6P	8P	2P	4P	6P	8P	2P	4P	6P	8P	2P	4P	6P	8P
CXRT-315	Inlet	2	1	1	1	-5	-1	-1	-1	-9	3	3	3	0	-1	-1	-1	-4	-5	-5	-5	-8	-10	-10	-10	-10	-11	-11	-11	-16	-16	-16	-16
	Outlet	-10	-7	-7	-7	-12	-8	-8	-8	-9	-5	-5	-5	-9	-9	-9	-9	-10	-12	-12	-12	-15	-14	-14	-14	-23	-23	-23	-23	-35	-32	-32	-32
	Radiated	-10	-7	-7	-7	-12	-8	-8	-8	-9	-5	-5	-5	-9	-9	-9	-9	-10	-12	-12	-12	-15	-14	-14	-14	-23	-23	-23	-23	-35	-32	-32	-32
CXRT-355	Inlet	-2	2	2	2	-4	0	0	0	-8	1	1	1	-1	-1	-1	-1	-4	-5	-5	-5	-8	-9	-9	-9	-10	-10	-10	-10	-16	-14	-14	-14
	Outlet	-1	1	1	1	-3	0	0	0	-6	3	3	3	-2	-4	-4	-4	-5	-6	-6	-6	-7	-8	-8	-8	-12	-14	-14	-14	-16	-17	-17	-17
	Radiated	-9	-7	-7	-7	-10	-7	-7	-7	-9	-4	-4	-4	-8	-9	-9	-9	-11	-11	-11	-11	-14	-14	-14	-14	-23	-22	-22	-22	-35	-32	-32	-32
CXRT-400	Inlet	-1	2	2	2	-4	0	0	0	-10	-2	-2	-2	-2	-3	-3	-3	-4	-6	-6	-6	-6	-9	-9	-9	-8	-11	-11	-11	-15	-11	-11	-11
	Outlet	-1	1	1	1	-3	-2	-2	-2	-7	2	2	2	-2	-5	-5	-5	-5	-5	-5	-5	-7	-8	-8	-8	-12	-15	-15	-15	-17	-18	-18	-18
	Radiated	-10	-7	-7	-7	-13	-9	-9	-9	-10	-6	-6	-6	-9	-10	-10	-10	-9	-10	-10	-10	-15	-14	-14	-14	-23	-23	-23	-23	-36	-33	-33	-33
CXRT-450	Inlet	-	2	4	4	-	-1	3	3	-	0	0	0	-	-3	-3	-3	-	-5	-4	-4	-	-8	-9	-9	-	-10	-12	-12	-	-13	-14	-14
	Outlet	-	-2	0	0	-	-1	5	5	-	3	2	2	-	-3	-3	-3	-	-6	-6	-6	-	-9	-9	-9	-	-14	-14	-14	-	-17	-18	-18
	Radiated	-	-10	-8	-8	-	-8	-5	-5	-	-6	-6	-6	-	-10	-8	-8	-	-12	-11	-11	-	-16	-15	-15	-	-25	-22	-22	-	-36	-33	-33
CXRT-500	Inlet	-	1	4	4	-	-2	2	2	-	1	-1	-1	-	-4	-3	-3	-	-4	-3	-3	-	-8	-10	-10	-	-11	-13	-13	-	-16	-17	-17
	Outlet	-	-4	-4	-4	-	0	5	5	-	3	2	2	-	-5	-5	-5	-	-5	-5	-5	-	-9	-9	-9	-	-14	-14	-14	-	-17	-19	-19
	Radiated	-	-12	-12	-12	-	-7	-6	-6	-	-5	-7	-7	-	-12	-10	-10	-	-11	-10	-10	-	-16	-15	-15	-	-25	-22	-22	-	-36	-34	-34
CXRT-560	Inlet	-	-2	0	0	-	-3	3	3	-	1	0	0	-	-6	-5	-5	-	-3	-3	-3	-	-8	-8	-8	-	-12	-12	-12	-	-15	-15	-15
	Outlet	-	-5	-5	-5	-	-2	4	4	-	2	1	1	-	-5	-5	-5	-	-4	-4	-4	-	-9	-9	-9	-	-14	-14	-14	-	-17	-18	-18
	Radiated	-	-13	-13	-13	-	-9	-5	-5	-	-5	-7	-7	-	-12	-10	-10	-	-10	-9	-9	-	-16	-15	-15	-	-25	-22	-22	-	-36	-33	-33
CXRT-630	Inlet	-	-5	-5	-4	-	-4	-4	3	-	1	1	0	-	-8	-8	-7	-	-3	-3	-3	-	-9	-9	-9	-	-13	-13	-11	-	-14	-14	-14
	Outlet	-	-6	-6	-5	-	-4	-4	3	-	1	1	0	-	-5	-5	-5	-	-4	-4	-4	-	-8	-8	-8	-	-14	-14	-14	-	-17	-17	-17
	Radiated	-	-14	-14	-13	-	-11	-11	-6	-	-7	-7	-7	-	-10	-10	-10	-	-9	-9	-9	-	-14	-14	-14	-	-22	-22	-22	-	-32	-32	-32
CXRT-710	Inlet	-	-3	-3	-3	-	-5	-5	2	-	0	0	-1	-	-7	-7	-6	-	-5	-5	-5	-	-10	-10	-9	-	-14	-14	-14	-	-19	-19	-19
	Outlet	-	-5	-5	-5	-	-6	-6	2	-	-1	-1	-1	-	-4	-4	-4	-	-3	-3	-4	-	-9	-9	-9	-	-15	-15	-14	-	-20	-20	-20
	Radiated	-	-13	-13	-13	-	-13	-13	-6	-	-7	-7	-7	-	-9	-9	-9	-	-8	-8	-9	-	-15	-15	-15	-	-23	-23	-22	-	-35	-35	-35

PERFORMANCE CURVES

- q_v : Airflow in m^3/h and m^3/s .
- p_{st} : Static pressure in mmWG and Pa.
- Dry air at 20°C and 760 mmHg.
- Performance data in accordance with ISO 5801 and AMCA 210-99 Standards.

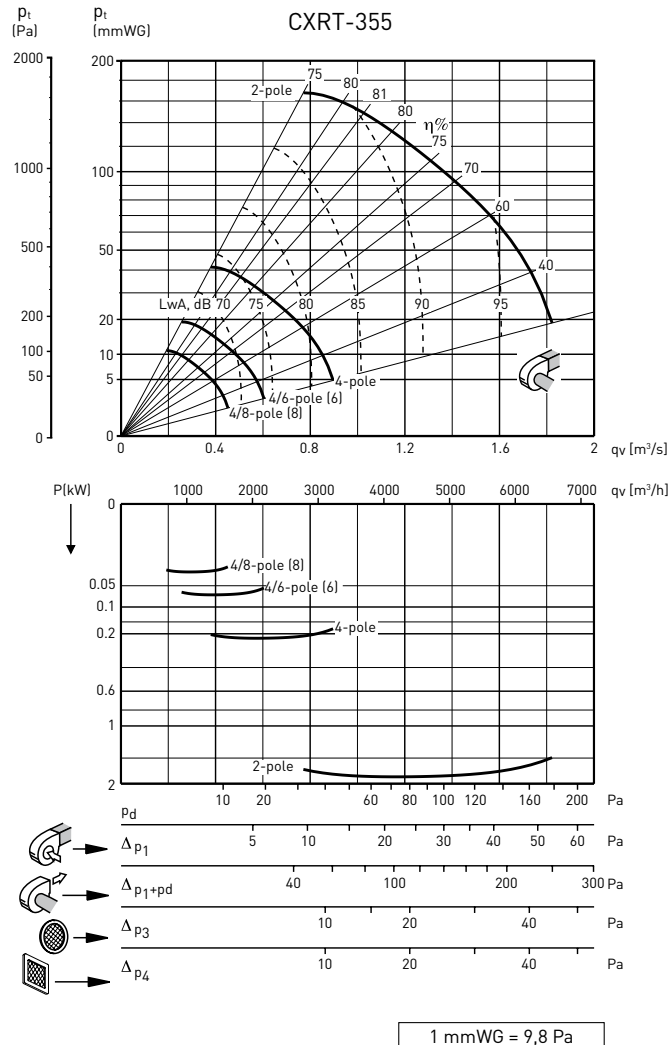
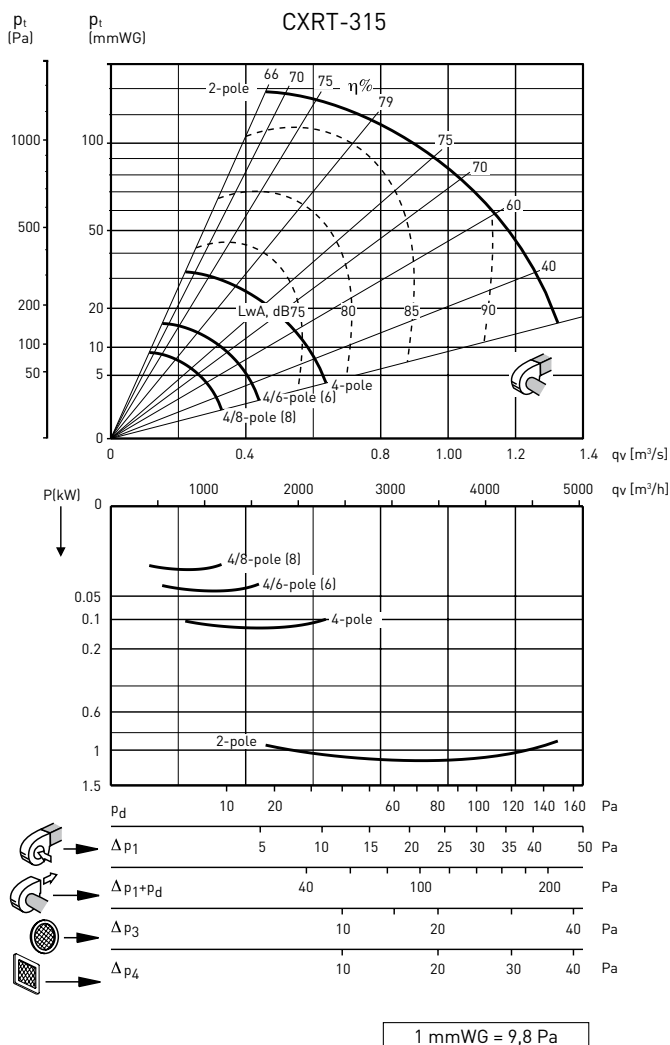

PERFORMANCE CURVES

- q_v : Airflow in m^3/h and m^3/s .
- p_{st} : Static pressure in mmWG and Pa.
- Dry air at $20^\circ C$ and 760 mmHg.
- Performance data in accordance with ISO 5801 and AMCA 210-99 Standards.

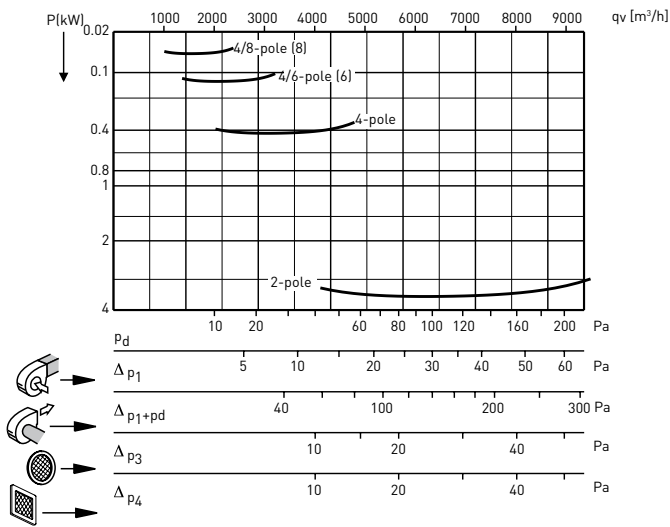
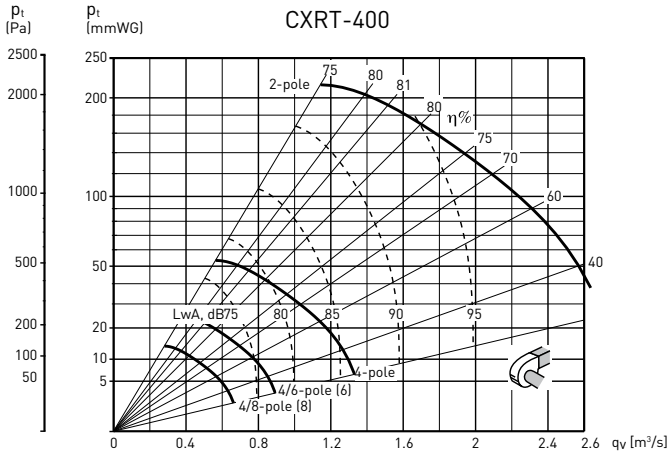

1 mmWG = 9,8 Pa

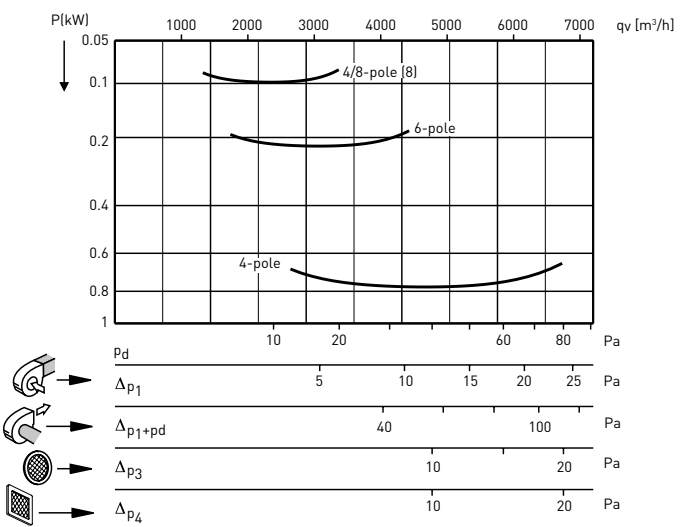
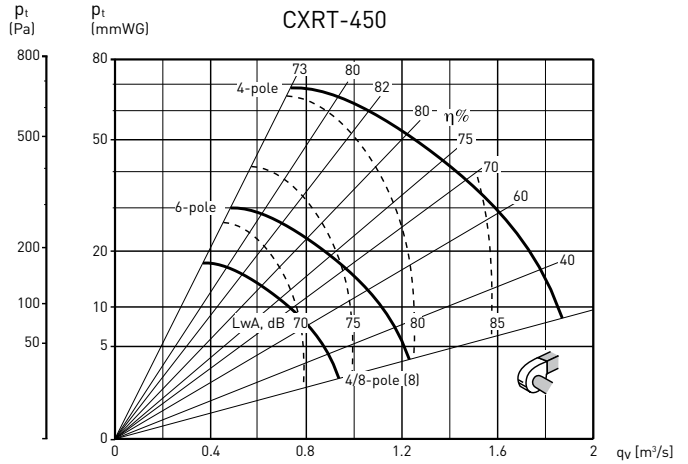

1 mmWG = 9,8 Pa

PERFORMANCE CURVES

- q_v : Airflow in m^3/h and m^3/s .
- p_{st} : Static pressure in mmWG and Pa.
- Dry air at $20^\circ C$ and 760 mmHg.
- Performance data in accordance with ISO 5801 and AMCA 210-99 Standards.

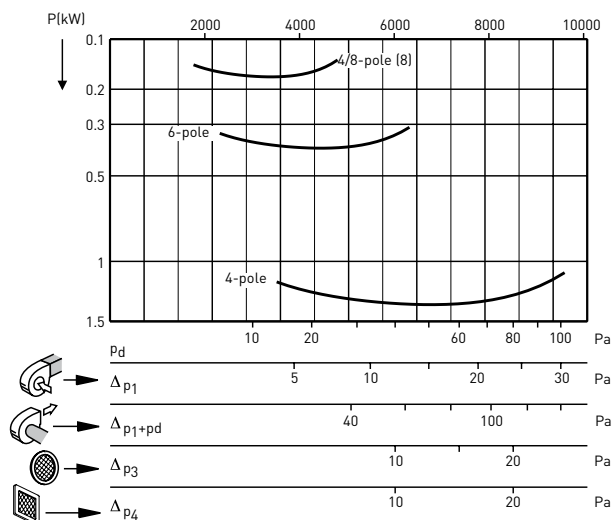
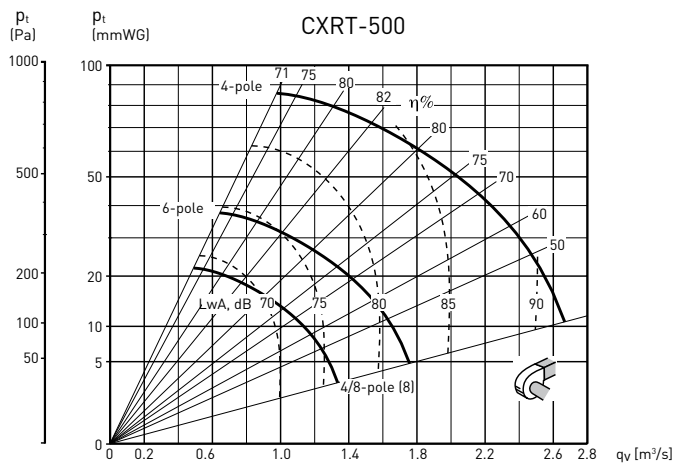

1 mmWG = 9,8 Pa

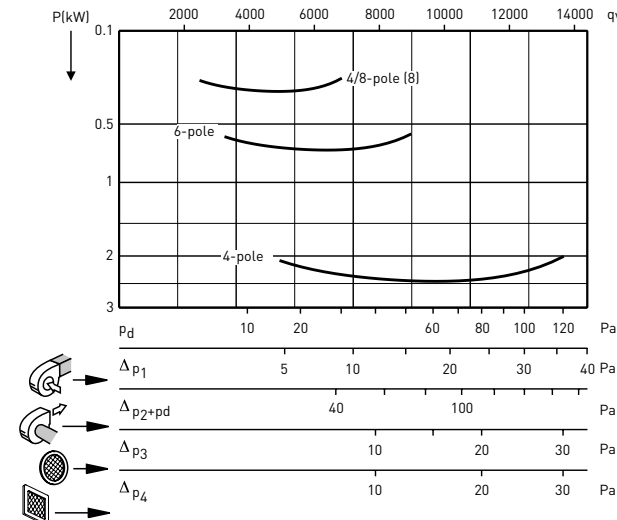
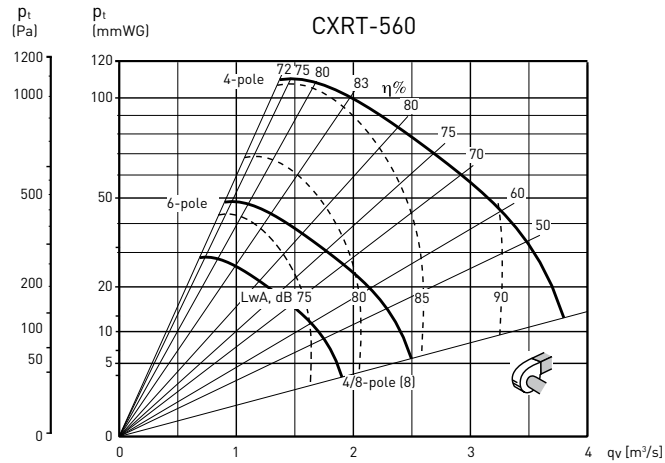

1 mmWG = 9,8 Pa

PERFORMANCE CURVES

- q_v : Airflow in m^3/h and m^3/s .
- p_{st} : Static pressure in mmWG and Pa.
- Dry air at 20°C and 760 mmHg.
- Performance data in accordance with ISO 5801 and AMCA 210-99 Standards.

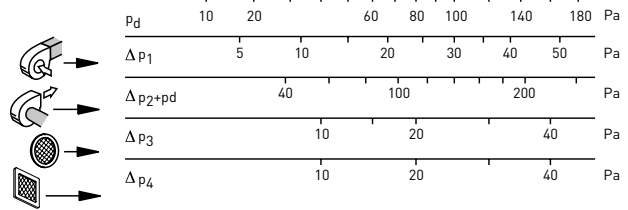
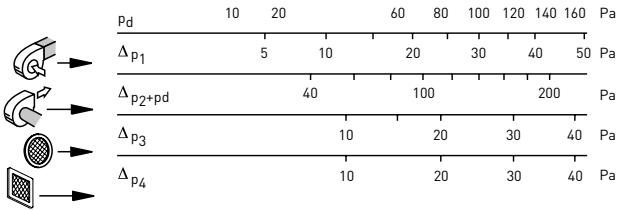
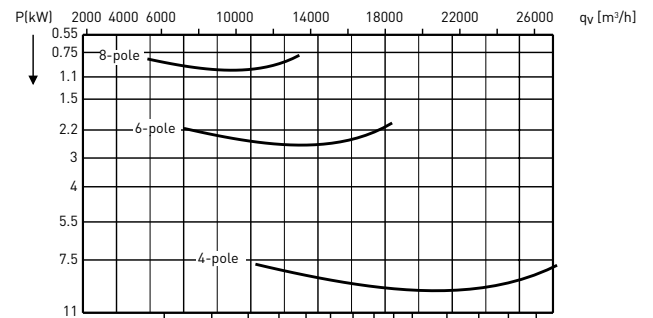
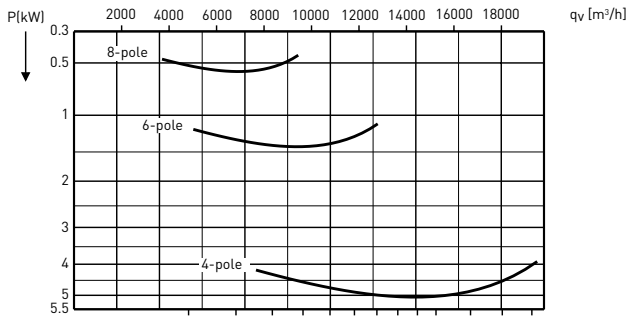
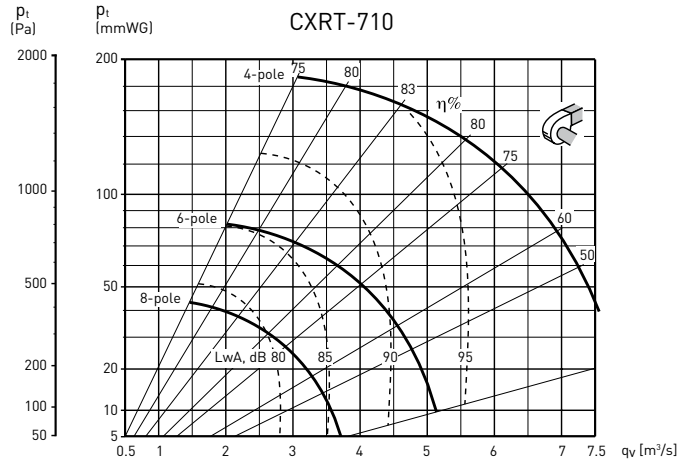
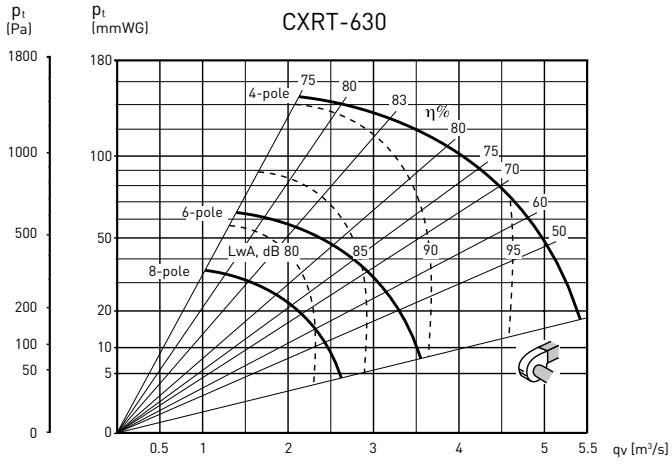

1 mmWG = 9,8 Pa

1 mmWG = 9,8 Pa

ACCESSORIES



KRXD
 Rectangular guard for mounting at the CXRT fan outlet.

Model CXRT	Model KRXD	Model CXRT	Model KRXD
315	KRXD-315	500	KRXD-500
355	KRXD-355	560	KRXD-560
400	KRXD-400	630	KRXD-630
450	KRXD-450	710	KRXD-710



KRXA
 Proof guard for mounting at the CXRT fan inlet.

Model CXRT	Model KRXA	Model CXRT	Model KRXA
315	KRXA-315	500	KRXA-500
355	KRXA-355	560	KRXA-560
400	KRXA-400	630	KRXA-630
450	KRXA-450	710	KRXA-710



KXBD
 Outlet flange.

Model CXRT	Model KXBD	Model CXRT	Model KXBD
315	KXBD-315	500	KXBD-500
355	KXBD-355	560	KXBD-560
400	KXBD-400	630	KXBD-630
450	KXBD-450	710	KXBD-710

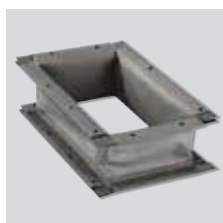

KAXD
 Rectangular flexible connector for mounting at the CXRT fan outlet.

Model CXRT	Model KAXD	Model CXRT	Model KAXD
315	KAXD-315	500	KAXD-500
355	KAXD-355	560	KAXD-560
400	KAXD-400	630	KAXD-630
450	KAXD-450	710	KAXD-710



ACOPEL F400 N *
 Circular flexible connector. Certified F400-120.

* For more information see Mounting Accessories.